

**PHILIPS**

Horticulture  
LED Solutions

GreenPower LED  
toplighting linear 2.2

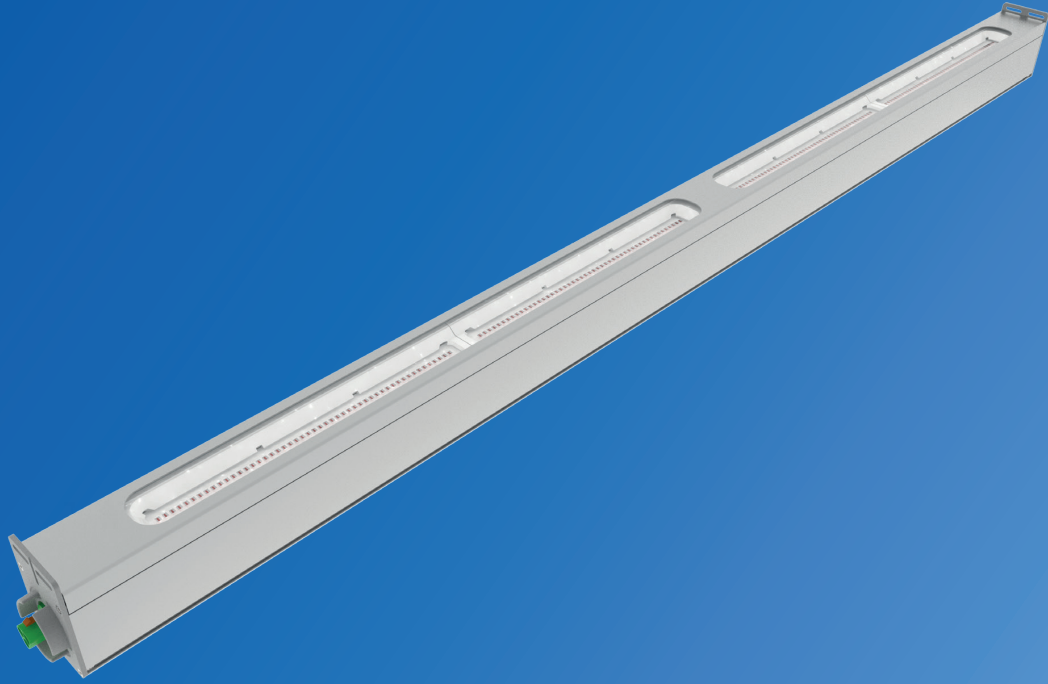

## Application Guide

# Break the barriers of yield and quality

October 2023

# Contents

<b>Introduction</b>	<b>3</b>
<b>Product information</b>	<b>4</b>
Technical specifications	4
Dimensions	5
<b>Installation of the system</b>	<b>6</b>
C-profile	6
Trellis	6
Continuous line installation	7
Non-continuous line installation	8
Connecting the system	10
Examples of max. number of interconnected modules	10
<b>Connection examples</b>	<b>13</b>
<b>Ordering data</b>	<b>16</b>
Modules	16
Accessories	17
Packaging toplighting 2.2	17
<b>Accessory information</b>	<b>18</b>
Accessories for module	18
<b>Crop protection and cleaning products</b>	<b>19</b>
Use of cleaning agents, crop protection products and other chemicals	19
Cleaning GreenPower LED products	19
<b>Compliance with international standards</b>	<b>20</b>

# Introduction

Especially designed for your growth system, the GreenPower LED toplighting linear module is the best solution for new or existing installations. Due to its high photon efficiency and long lifetime, the GreenPower LED toplighting linear module is the cost-effective way to improve climate and crop control for greenhouse applications.

**The GreenPower LED toplighting linear module gen 2.2 is available in 8 spectral versions. This Greenpower LED toplighting linear range consists out of 12 products. 7 products have a standard non dimmable photon flux, Static (S) products and 5 products have the option to tune the photon flux up and down, Dimmable (D) products. These five dimmable products need to be controlled via a Philips proprietary Coded Mains Dimming (CMD) protocol supported via the Philips GrowWise Control System (GCS). The GrowWise Control System is needed to activate, steer and drive the dimmable functionality of these 5 dimmable spectral versions. The Quick installation and Application Guide of the GrowWise Control System is accessible via the Philips Horticulture Partner Portal. This complete universal mains GreenPower LED toplighting range is outlined in the next chapter.**

For each type of installation, Trellis or C-profile mounted, continuous (interconnected modules) or non continuous line, dedicated accessories are available for an easy and quick installation.

This application guide describes all important technical and safety information of the GreenPower LED toplighting linear module.

# Product information

## Technical specifications

### GPL toplighting linear Gen 2.2 Dimmable

Name	Voltage VAC	Photon flux (μmol/s)	Power (W)	Efficacy typical <sup>1</sup> (μmol/J)
GPL TLL 800 DRB_LB 277-400V 2.2 D	277-400	800	230	3.5
GPL TLL 800 DRW_LB 277-400V 2.2 D	277-400	800	250	3.2
GPL TLL 800 DRW_MB 277-400V 2.2 D	277-400	800	250	3.2
GPL TLL 630 DRW_VSN2 277-400V 2.2 D	277-400	630	250	2.5
GPL TLL 720 DRW_EBW 277-400V 2.2 D	277-400	720	235	3.1

### GPL toplighting linear Gen 2.2 Static

Name	Voltage VAC	Photon flux (μmol/s)	Power (W)	Efficacy typical <sup>1</sup> (μmol/J)
GPL TLL 550 DRB_LB 200-400V 2.2 S	200-400	550	155	3.5
GPL TLL 550 DRB_MB 200-400V 2.2 S	200-400	550	160	3.4
GPL TLL 520 DRB_HB 200-400V 2.2 S	200-400	520	160	3.3
GPL TLL 550 DRW_LB 200-400V 2.2 S	200-400	520	155	3.4
GPL TLL 520 DRW_MB 200-400V 2.2 S	200-400	520	160	3.3
GPL TLL 500 DRWFR_2 200-400V 2.2 S	200-400	500	175	2.9
GPL TLL 500 DRW_VSN2 200-400V 2.2 S	200-400	500	200	2.5

## Specifications

Optical	
Rated average lifetime <sup>1,2</sup>	36.000 hrs, L90 (90% photon flux maintenance)
Electrical	
Input voltage toplighting linear Gen 2.2 Static	200-400 V~, 50/60Hz
Input voltage toplighting linear Gen 2.2 Dimmable	277-400 V~, 50/60Hz
Power factor	> 0.95
Inrush current	< I nominal, negligible
Total Harmonic Distortion	< 15%
Through wiring cross-section	AWG 14
Environment	
Ambient storage temperature	-40 - 85 °C (T <sub>storage</sub> )      -40 - 185 °F (T <sub>storage</sub> )
Ambient operating temperature	0 - 40 °C (T <sub>operating</sub> )      32 - 104 °F (T <sub>operating</sub> )
Max. case temperature <sup>1</sup>	65 °C (T <sub>case</sub> )      149 °F (T <sub>case</sub> )
Cooling	Passively air-cooled
Relative humidity	5 - 95% RH, no condensation allowed during storage, operation and application
Ingress protection rating	IP66
Photobiological hazard <sup>3</sup>	
Radiation hazard - Retinal Blue	Risk Group 2
All other radiation hazards <sup>4</sup>	Exempt group

**Note:** The dimmable products have the option to tune the photon flux between 10% and 100%. The efficacy for dimmable products is given for 100% photon flux. IP66 covers 100Kpa = 1 bar water pressure. To avoid damaged gaskets Signify advises NOT to clean this product with water power jets.

<sup>1</sup> Efficacy typical, Rated average lifetime and Max. case temperature, at T<sub>ambient</sub> = 25 °C / 77 °F.

<sup>2</sup> All measured lifetimes are industry standard measurements indicating average length of operation and not a performance claim specific to any individual product.

<sup>3</sup> For more information about photobiological hazard see page 5.

<sup>4</sup> Near ultraviolet hazard, Retinal thermal hazard and Infrared radiation hazard.

#### Legend:

GPL = GreenPower LED  
DR = Deep Red  
W = White  
LB = Low Blue

MB = Medium Blue  
VSN2 = Vision (broad spectrum)  
S = Static  
EBW = Efficient Broad White

TLL = toplighting linear  
B = Blue  
FR = Far Red

HB = High Blue  
2.2 = Generation  
D = Dimmable

## Dimensions

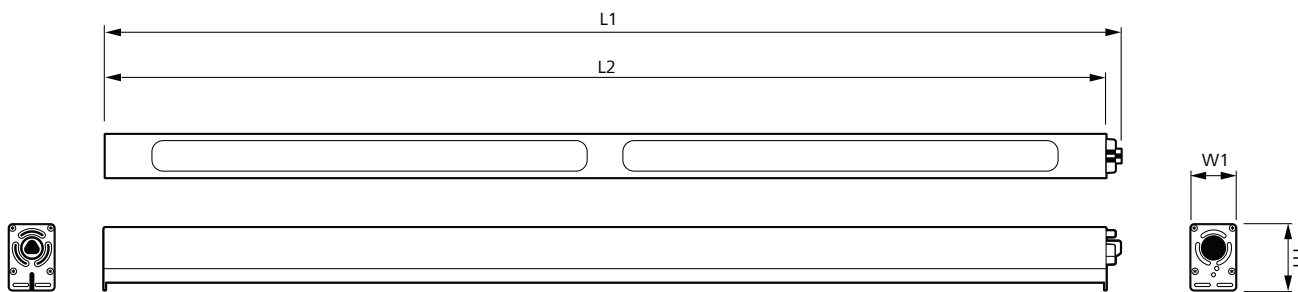

Product name	Product dimensions (mm)				Product weight (kg)
	L1	L2	W1	H1	
GPL TLL G2.2	1264	1248	55	80	3.25

## Important

### Influencing factors of light output

As ambient temperature increases, both the photon flux and the photon flux maintenance will decrease. Pollution or damage of optics will also impact the light output.

### Thermal protection

The GreenPower LED toplighting module has a built-in thermal protection device. If the temperature of the module becomes too high, at around 50°C ambient, the module will shut down. After cooling down, the module will switch on again automatically (results in blinking).

### Photobiological hazard

Photobiological safety of lamps and lamp systems (IEC 62471). This International Standard describes the photobiological safety of lamps and lamp systems including luminaires.

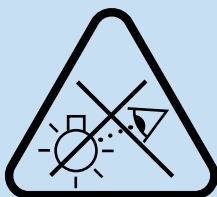

#### Risk Group 2:

Do not stare at the operating light source. The philosophical basis for this classification is that the lamp does not pose a hazard due to the aversion response to very bright light sources or due to the thermal discomfort.

#### Risk group 2

**Caution:** Possibly hazardous optical radiation emitted from this product. Do not stare at operating lamp. May be harmful to the eye.

Wear protective glasses which filter out blue radiation (400 - 500nm), if directly looking into the light source can not be avoided. The amount of blue light must be reduced by a factor of 10 (OD1) to 100 (OD2). Protective glasses with OD2 classification is recommended (OD stands for Optical Density).

### Light source not replaceable

The light source of this fixture is not replaceable. If the product becomes damaged or the light source reaches its end-of-life, the whole fixture needs to be replaced.

### Not for outdoor use

Modules are not suited to outdoor use and are not intended to be installed in stairways and horizontal travel paths.

# Installation of the system

The GreenPower LED toplighting linear generation 2.2 can be fitted very easily without the need for any tools and has been designed together with installers and growers to achieve a simple and quick installation. The module can be fixed to the greenhouse structure using the prescribed accessoires used for greenhouse installations.

If the Greenpower LED toplighting linear is mounted in a hybrid installation between traditional HPS lamps, verify heat dissipation and distance between both products. This to avoid overheating of the Greenpower LED toplighting linear module beyond its thermal specification, reducing its lifetime. The linear toplighting is designed to achieve the ultimate light uniformity in all greenhouse applications. Therefore depending on the required photon flux density ( $\mu\text{mol/s/m}^2$ ) and the installation height, the Greenpower LED toplighting linear modules can be connected in a continuous line, or a non-continuous line. The Greenpower LED toplighting linear modules should always be positioned in a horizontal position above the crop, to achieve optimal light uniformity.

The Greenpower LED toplighting linear should be mounted on a C-profile or strut, or directly to the trellis of the greenhouse structure, using the specific trellis brackets. Thanks to the head-to-tail interconnection, a stress free connector construction and the stainless steel clips, it is virtually a plug-and-play installation method.

## C-profile

Mount 40x40 mm C-profiles to the greenhouse structure at the required height. During assembly use a fixation which uses the inside of the C-profile (solid green line). Make sure that the deflection of the mounting profile is max 10 mm. **Pay attention to hooks mounted around the profile (dotted red line), as they could interfere with brackets type (A).** Use the specific bracket (A) ([see Accessory information](#)) to mount the modules on the C-profile!

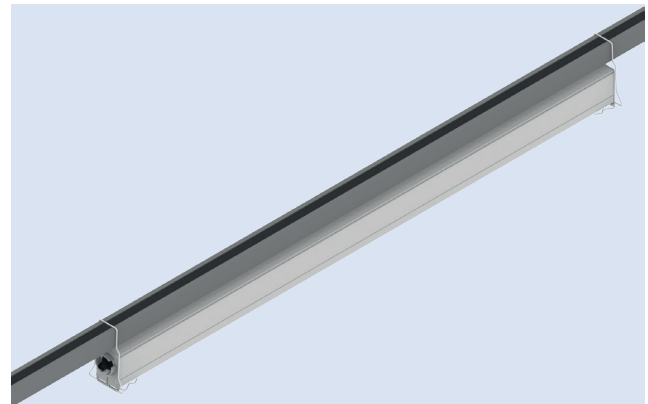
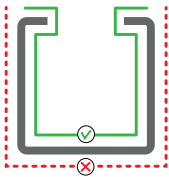

C-profile

## Trellis

The width of the rectangular profile must be known, in order to choose the correct trellis mounting bracket (see Accessory information). There are two mounting brackets available, one for mounting on a 50mm (B) and one for mounting on a 60mm (C) trellis rectangular steel profile. The steps to take for a continuous and non-continuous line installation are explained for mounting on a C-profile and also apply for the trellis rectangular steel profile.

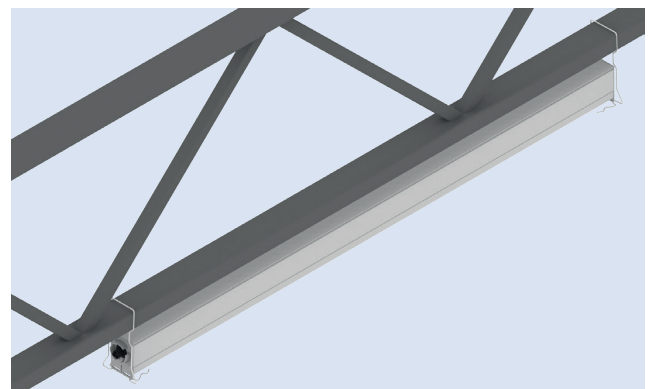

Trellis

## Continuous line installation

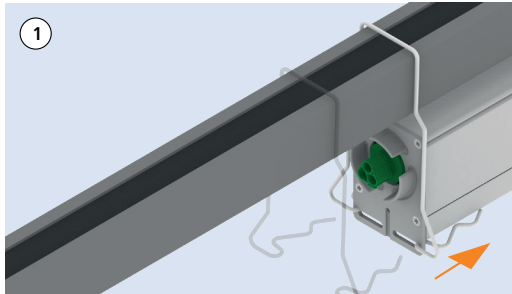
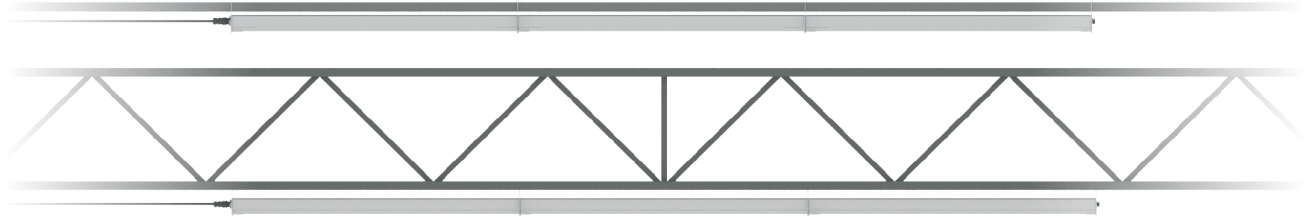

1) Hook on 2 mounting brackets (**A and A**) onto the C-profile at 1.25m pitch. Put the 1st module against the C-profile. Slide both brackets horizontal into both metal end caps of the module.

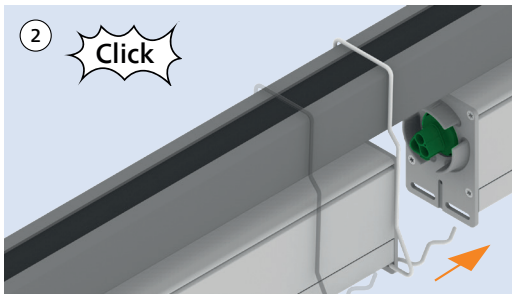

2) Hook the next bracket (**A**) onto the C-profile at 1.25 m distance. Put the 2nd module against the C-profile. Slide the 2nd module over bracket (**A**). Connect both modules, verify that these 2 modules are snapped together correctly (**CLICK**) and check if bracket (**A**) snaps into both end caps of the modules.

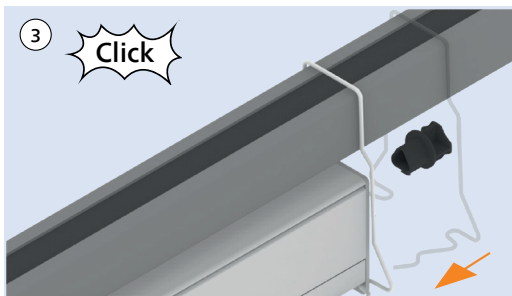

3) Repeat step 2 until the maximum permissible number of modules is reached. **For the maximum number of modules allowed per phase, see page 10 and 11.** Slide the final mounting bracket (**A**) into the last module. **IMPORTANT:** Put the plastic end cap at the end of a through wire line (**CLICK**) to comply to IP66, no dewing allowed.

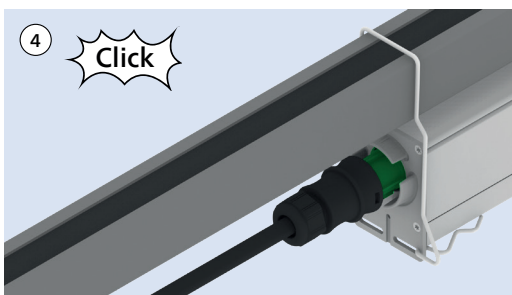

4) Connect the female connector to the main power cable (**CLICK**) and connect this main power cable to the power grid.

## Non-continuous line installation

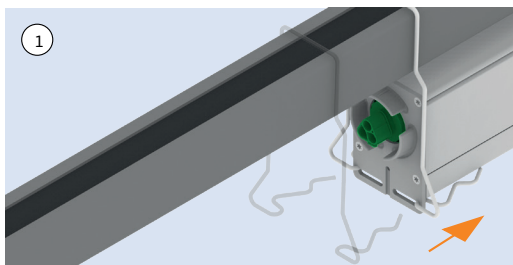
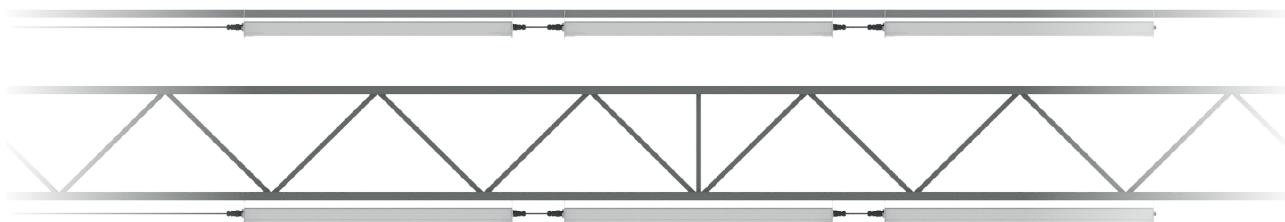

1) Hook on 2 mounting brackets (**A and A**) onto the C-profile. Put the 1st module against the C-profile. Slide the 1st bracket (**A**) horizontal into both metal end caps of the module.

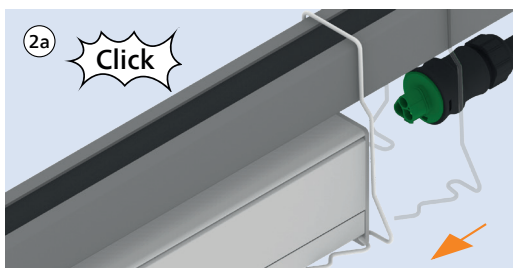

2) Slide the 2nd bracket (**A**) into the end cap of the 1st module. Hook the 3rd and 4th bracket (**A**) onto the C-profile. Put the 2nd module against the C-profile. Slide the 3rd and 4th bracket (**A**) into the end caps of the 2nd module. Connect both modules, using a jumper cable assembly and verify that the jumper cable is snapped onto the connectors correctly (**CLICK**).

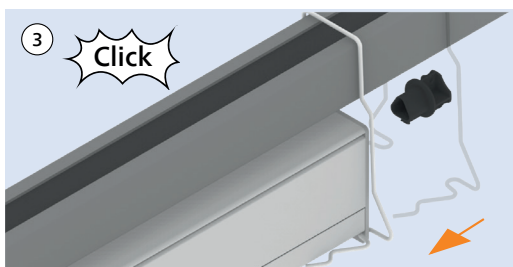
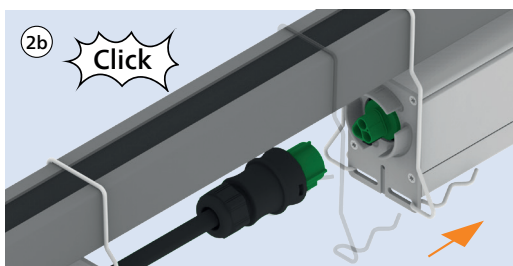

3) Repeat step 2 until the maximum permissible number of modules is reached. **For the maximum number of modules allowed per phase, see page 10 and 11.** Slide the final bracket (**A**) into the last module. **IMPORTANT:** Put the plastic end cap into the female connector (**CLICK**) of every last module, to comply to IP66, no dewing allowed.

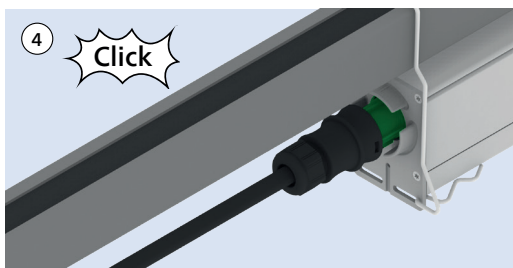

4) Connect the female connector to the main power cable (**CLICK**) and connect this main power cable to the power grid.



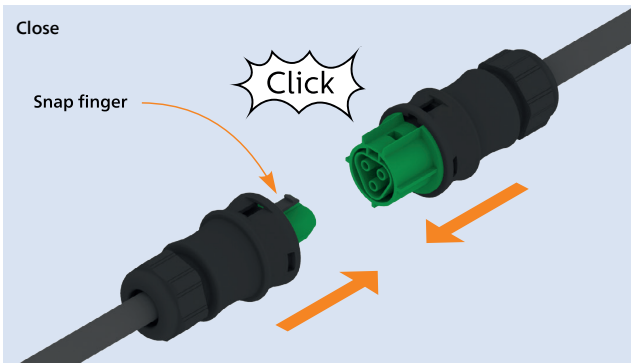

### Use of the connector

The connectors lock automatically when plugged together and give the user clear feedback on the correct end position. Plug and push both connectors until it clicks. **Ensure that it clicks to guarantee a correct electrical connection and ingress protection. The connectors are not for current interrupting, never connect or disconnect the connectors under load!**

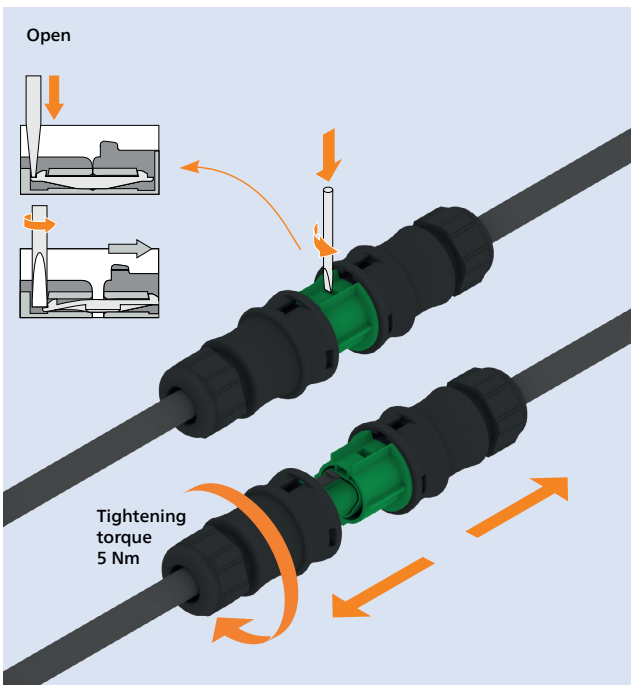

For unlocking the connectors (and plastic end caps), press and twist the snap finger, by means of a DIN 5264A, 3.5 mm screwdriver. For unlocking modules when interconnected, pull both modules in opposite direction. The snap fingers supplied with the male connector of the modules are designed to do this easily with a small pull force.

### Wiring connectors and custom cables

The housing of the female connector has been designed in three parts. In case of assembling a field installable main power cable assembly, use cable diameters between 10-14 mm. Make sure the screw connection is tightened with a torque of 5 Nm. **Always keep ingress protection IP66 in mind, this also needs to be secured during assembly and operation. IP66 protection from the electrical cabinets containing electrical components and cabling, to the final connection between both male-female Wieland RST20i 3-pole connectors.** Follow the assembly instructions, which are available from the connector supplier Wieland Electric GmbH - [www.wieland-electric.com](http://www.wieland-electric.com)

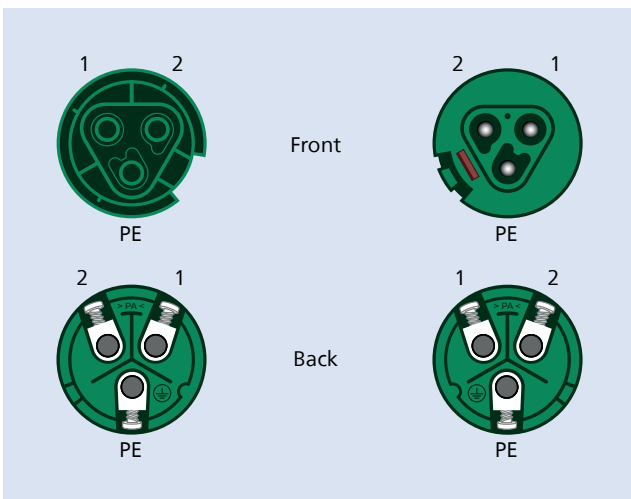

For Line to Line and Line to Neutral voltage configurations, several options are presented with respect to the pins of the female connector of the main power cable and the male RST20i-3pole connector of the toplighting module.

Pin	Line to Line voltage			Line to Neutral voltage		
	L1	L1	L2	L1	L2	L3
1	L2	L3	L3	N	N	N
2	PE	PE	PE	PE	PE	PE

**Legend:**  
 L = Line  
 N = Neutral  
 PE = Protective Earth

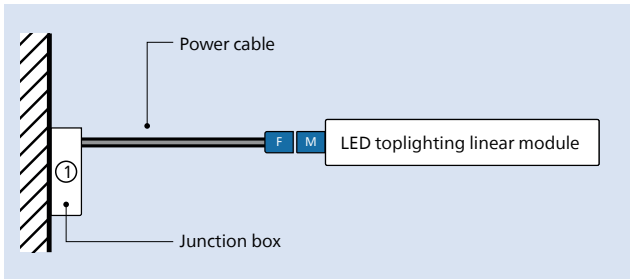

### Connecting the system

Connect all power cables to a junction box, rated for wet or damp locations. Make sure all junction boxes are mounted to a rigid structure. Cables must be secured by a cord grip / strain relief. Use a cord grip suitable for use with three conductor and type off cord suitable for the trade size of the junction box provided by others, if needed. Any unused connector must be secured and sealed with an end cap (see ordering data). Otherwise the IP66 rating will be void.

### Connecting the system

#### Legend

- F = Female connector of the power cable
- M = Male connector of the first module

### Examples of max. number of interconnected modules

There are several options for connecting the Static and Dimmable modules to the mains, 200-400V~ for the Static modules and 277-400V~ for the Dimmable modules, and determining the maximum number of modules, which depend on the power consumption of the LED module, the type of installation (continuous or non continuous line), the number of circuit breakers, the circuit breaker type (1-pole/2-pole/3-pole or 4-pole), the cross-section (mm<sup>2</sup>) and material of the cable conductors, the total length of the cable conductors and the use of an earth leakage protection (RCD)<sup>1</sup>. Examples for the maximum number of interconnected modules (continuous line), are presented below. For continuous and non-continuous line installations, always check the maximum allowed/protected cable length<sup>1</sup>. These tables only give indication about the maximum allowed interconnected toplighting modules. A certified electrical installer must make the final decision, in accordance with all applicable international, national and local electrical and construction codes, norms and regulations.

Mains Voltage (V~)	Power (W)	System	Max # of modules per phase pair	
			15A Circuit breaker <sup>2</sup>	
			1x3P	3x2P
208	155	L-L	9	16
	160	L-L	9	15
	175	L-L	8	14
	200	L-L	7	12
240	155	L-L	10	18
	160	L-L	10	18
	175	L-L	9	16
	200	L-L	8	14
277	155	L-N	21	
	160	L-N	20	
	175	L-N	18	
	200	L-N	16	
	230	L-N	14	
	235	L-N	14	
347	250	L-N	13	
	155	L-N	26	NA
	160	L-N	26	
	175	L-N	23	
	200	L-N	20	
	230	L-N	18	
	235	L-N	17	
	250	L-N	16	

#### Legend

- L = Line
- N = Neutral
- NA = Not Applicable
- 2P = 2 Pole breaker type
- 3P = 3 Pole breaker type
- RCD = Residual-Current Device

<sup>1</sup> A multiplication factor of  $\sqrt{3}$  can be used for determining the maximum protected cable length, if short circuit between Line-Protective Earth or Line-Earth is not possible (IEC60364).  
<sup>2</sup> 20A circuit breakers could be considered at the discretion of the certified electrical installer.

Mains Voltage (V~)	Power (W)	System	Max # of modules per phase pair			
			16A C-type		20A B-type	
			1x3P	3x2P	1x3P	3x2P
200	155	L-L	9	16	11	20
	160	L-L	9	16	11	20
	175	L-L	8	14	10	18
	200	L-L	7	12	9	16
220	155	L-L	18		22	
	160	L-L	17		22	
	175	L-L	16		20	
	200	L-L	14		17	
230	155	L-N	18	NA	23	NA
	160	L-N	18		23	
	175	L-N	16		21	
	200	L-N	14		18	
380	155	L-L	18	31	22	39
	160	L-L	17	30	21	38
	175	L-L	16	27	20	34
	200	L-L	14	24	17	30
	230	L-L	12	21	15	26
	235	L-L	11	20	14	25
	250	L-L	11	19	14	24
400	155	L-L	19	33	23	41
	160	L-L	18	32	23	40
	175	L-L	16	29	21	36
	200	L-L	14	25	18	32
	230	L-L	12	22	16	27
	235	L-L	12	21	15	27
	250	L-L	11	20	14	25

**Legend:**

- L = Line
- N = Neutral
- NA = Not Applicable
- 2P = 2 Pole breaker type
- 3P = 3 Pole breaker type

## Important

### **Turn off and disconnect the power before installation.**

Installation must be performed by a qualified electrician in accordance with all national and local electrical and construction codes and regulations.

- **DO NOT** attempt to install or use until you have read and understood the installation instructions of this product contained in the Quick Installation Guide, this Application Guide and safety labels.
- Make sure that power cords are routed in a manner that will prevent incidental damage.
- Use wet-rated (IP66) junction boxes which are also suitable for the power cords used in the application.
- Use a strain-relief or power cord grip if needed.
- Use a cord grip suitable for use with three conductor and type off cord suitable for the trade size of the junction box provided by others, if needed.
- **DO NOT** connect to live power until installation is complete.
- **DO NOT** modify or alter the product; doing so will void the warranty.

### **Connection of power grid to first module**

Wieland female connector should apply with H07RN-F 3x2.5 mm<sup>2</sup> power cable with a diameter > 10 mm. In case of not using a Philips jumper cable with factory-made crimp and sleeve connectors, be aware of the following: H07RN-F 3x2.5 mm<sup>2</sup> power cable with a diameter > 10 mm applies when creating a through-wiring by using a Wieland male and female field installable connector. Please follow Wieland's instructions, if not, the LED system warranty will be void!

### **IP66**

Make sure the connection to the power is made in such a way it is suitable for wet conditions (e.g. use a wet-rated (IP66) junction box).

### **Internal wiring**

The internal wiring of the toplighting linear gen 2.2 module is AWG 14.

### **Possible "LED glow effect" in standby or after switch-off of the module.**

For Coded Mains Dimmable products, the light output is adjustable between 10 and 100%. Switch-on and switch-off should preferably be done via a mains switch. When installing Coded Mains Dimmable products in combination with the GrowWise Control System (GCS), the user interface will not allow dim values below 10%. Also, standby mode will not be available as a standard default setting.

The reason for this setting is that the LEDs in these modules can show a slight 'glow effect' when being in standby (0% dimming) or when switching off the mains in a standby situation. This is a result of a very small capacitive leakage current, resulting in a visible 'glow' when being in standby or a visible 'glow' for several minutes after switching off the mains while being in standby. This effect will not damage the module and does not lead to an unsafe situation.

If needed, there are three options to go to zero light:

- In the situation where the system is connected to a climate computer, the mains power should be switched by this climate computer. When light should be turned off, the climate computer can switch off the modules, resulting in no glow nor standby losses. This is the preferred solution.
- Activate standby mode in the GrowWise Control System and accept the glow-effect and standby losses. Please consult your Signify representative to get this option activated.
- In case of a standalone GrowWise Control System (GCS), the end user/installer will need to install a separate (hardware) switch, to switch off mains power to the modules. There will be no glow effect nor standby losses.

# Connection examples

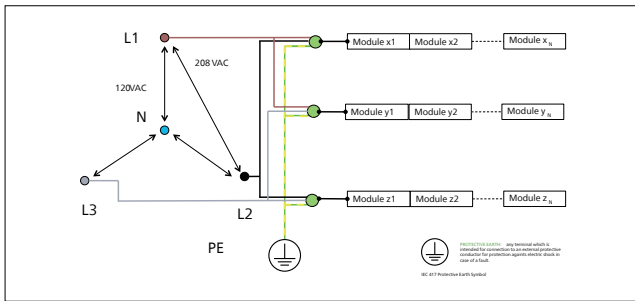

208V~ connection between phases (208V~ power grid)

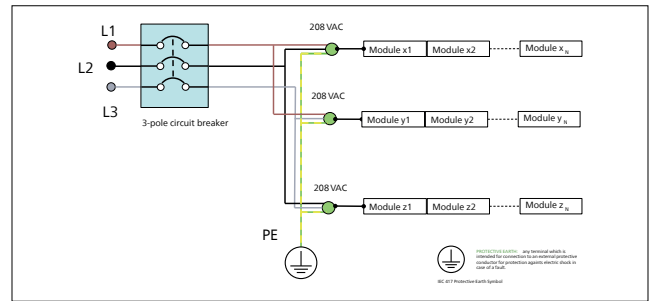

208V~ connection between phases (208V~ power grid)

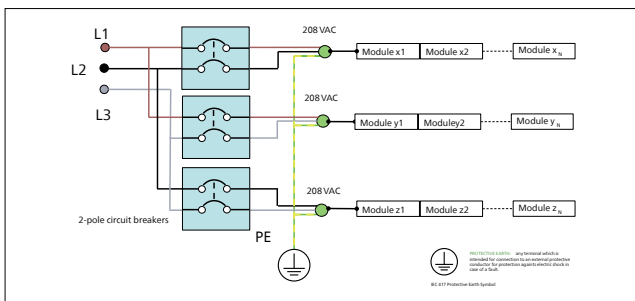

208V~ connection between phases (208V~ power grid)

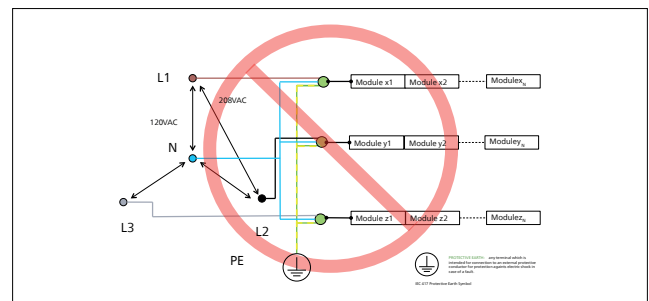

120V~ connection between neutral and phase (208V~ power grid)

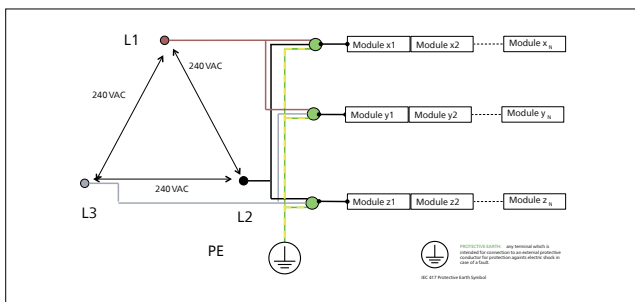

240V~ connection between phases (240V~ power grid)

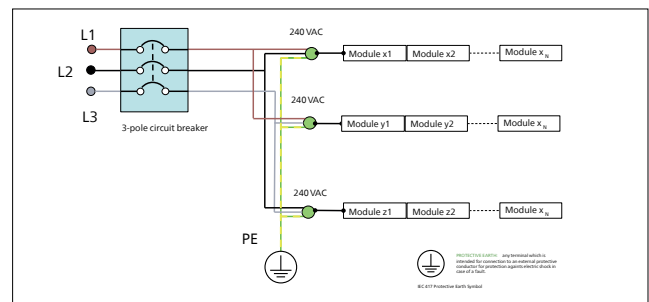

240V~ connection between phases (240V~ power grid)

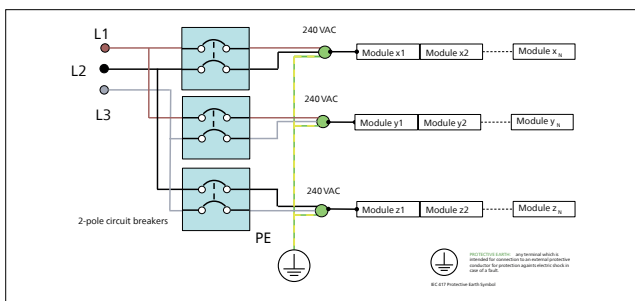

240V~ connection between phases (240V~ power grid)

**Note:**

The Dimmable modules operate between 277-400V, thus the schemes for 208V~ and 240V~ are not applicable to the Dimmable modules.

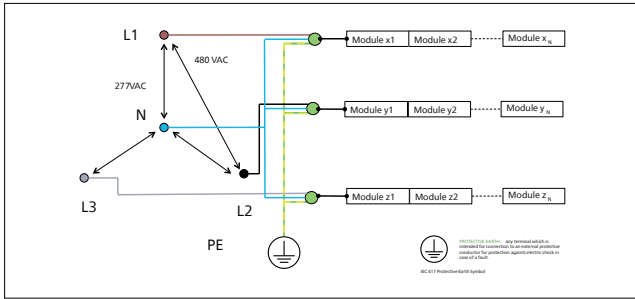

277V~ connection between phase and neutral (480V~ power grid)

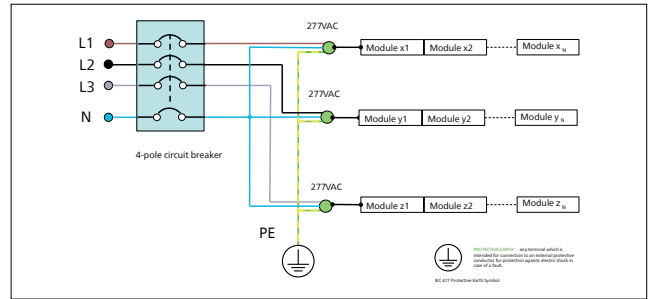

277V~ connection between phase and neutral (480V~ power grid)

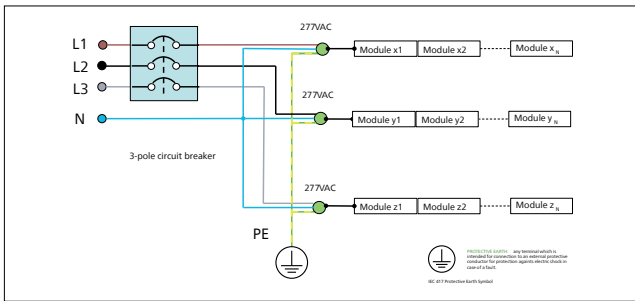

277V~ connection between phase and neutral (480V~ power grid)

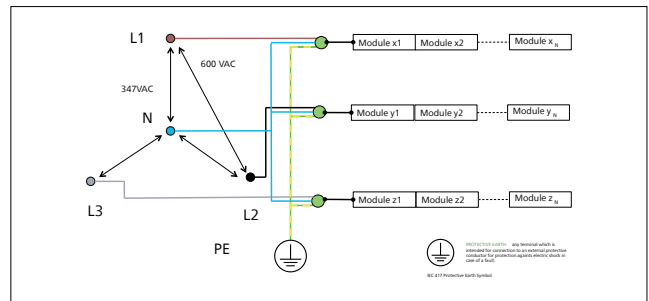

347V~ connection between phase and neutral (600V~ power grid)

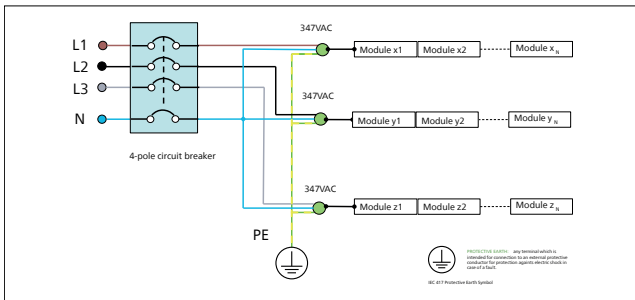

347V~ connection between phase and neutral (600V~ power grid)

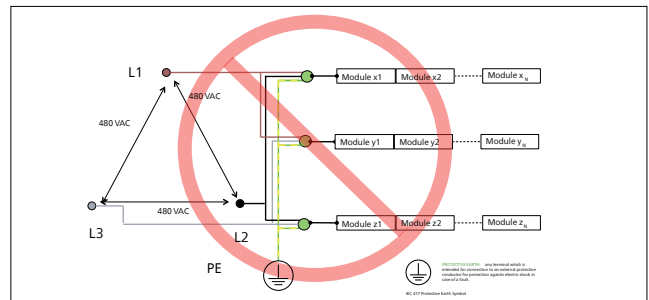

480V~ connection between phases (480V~ power grid)

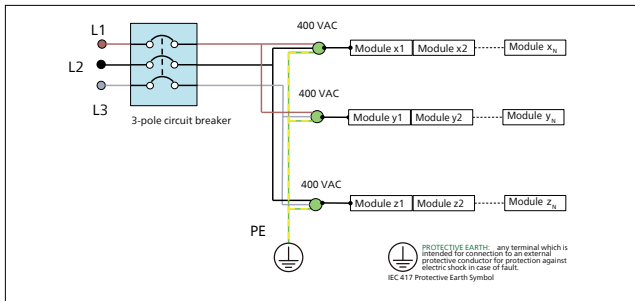

400 V~ connection between phases (400 V~ power grid).

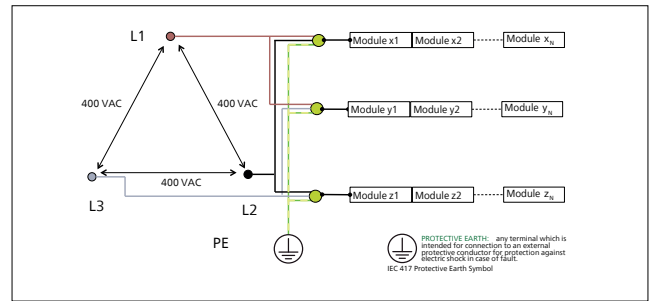

400 V~ connection between phases (400 V~ power grid).

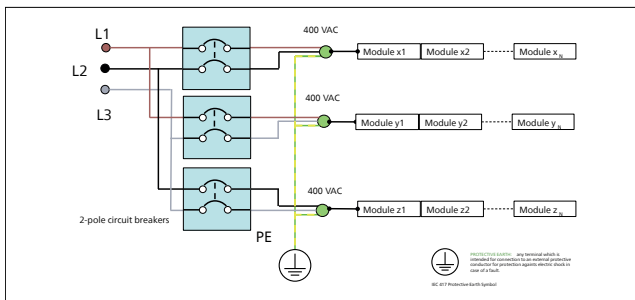

400 V~ connection between phases (400 V~ power grid).

## ⚠ Important

- Use of 690 V~ systems is prohibited because the safety isolation is not designed for these high voltages!
- If interconnection cables are used the total length of the conductors will be limiting.
- The circuit breaker type needed and maximum number of modules depend on connection cable diameters and total protected length.
  - The connection wires used inside the module: diameter = 2.08mm<sup>2</sup>, AWG14
  - The jumper cables EU/Rest of world: diameter = 1.5mm<sup>2</sup>
  - The jumper cables US/Canada: diameter = 2.08mm<sup>2</sup>, AWG14

# Ordering data

## Modules

Product description	12NC	6 NC
<b>GPL toplighting linear gen 2.2 Static</b>		
<b>Deep red/blue (DR/B)</b>		
GPL TLL 550 DRB_LB 200-400V 2.2 S	9290 021 00459	364323
GPL TLL 550 DRB_MB 200-400V 2.2 S	9290 021 00460	364331
GPL TLL 520 DRB_HB 200-400V 2.2 S	9290 021 00461	364349
<b>Deep red/ white (DR/W)</b>		
GPL TLL 550 DRW_LB 200-400V 2.2 S	9290 021 00462	364356
GPL TLL 520 DRW_MB 200-400V 2.2 S	9290 021 00463	364372
GPL TLL 500 DRW_VSN2 200-400V 2.2 S	9290 021 00465	364398
<b>Deep red/ white/far red (DR/W/FR)</b>		
GPL TLL 500 DRWFR_2 200-400V 2.2 S	9290 021 00464	364380
<b>GPL toplighting linear gen 2.2 Dimmable</b>		
<b>Deep red/blue (DR/B)</b>		
GPL TLL 800 DRB_LB 277-400V 2.2 D	9290 021 00455	364406
<b>Deep red/ white (DR/W)</b>		
GPL TLL 800 DRW_LB 277-400V 2.2 D	9290 021 00456	364414
GPL TLL 800 DRW_MB 277-400V 2.2 D	9290 021 00457	364422
GPL TLL 630 DRW_VSN2 277-400V 2.2 D	9290 021 00458	364430
GPL TLL 720 DRW_EBW 277-400V 2.2 D	9290 021 00996	371039



# Ordering data

## Accessories

Product description	12NC	6 NC
<b>Mounting bracket for module</b>		
GPL bracket toplight NAM <sup>1</sup>	9290 015 08106	303925
GPL bracket toplight 2.0/2.1 TRE 50 <sup>1,2</sup>	9290 016 79306	343327
GPL bracket toplight_2.0/2.1 TRE 60 <sup>1,3</sup>	9290 016 79406	343345
<b>Power connector for module</b>		
GPL toplighting male connector	9290 009 15406	
GPL toplighting female connector	9290 009 15506	
<b>Power cable for module, US/Canada</b>		
GPL toplighting main power cable	9290 015 16206	304188
GPL toplighting jumper NAM 6.6ft <sup>4</sup>	9290 015 08206	303933
GPL toplighting jumper NAM 3.3ft <sup>4</sup>	9290 015 55806	324061
<b>Power cable for module, EU/ROW</b>		
GreenPower LED toplighting jumper cable (1.0 mtr) <sup>5</sup>	9290 009 15306	
GreenPower LED toplighting jumper cable (2.0 mtr) <sup>5</sup>	9290 009 16006	
<b>End cap</b>		
GreenPower LED toplighting end cap <sup>6</sup>	9290 009 15606	303966

## Packaging toplighting 2.2

Box dimensions	Pcs per box	Pallet dimensions	Pcs per pallet
1.35 m x 0.77 m x 0.12 m	4	1.35 m x 0.77 m x 1.255 m	144 (4 boxes per layer / 9 layers per pallet)

### Legend:

GPL = GreenPower LED  
 TLL = toplighting linear  
 DR = Deep Red  
 B = Blue  
 W = White  
 VSN2 = Vision (broad spectrum)  
 EBW = Efficient Broad White

FR = Far Red  
 LB = Low Blue  
 MB = Medium Blue  
 HB = High Blue  
 2.2 = Generation  
 S = Static  
 D = Dimmable  
 TRE = Trellis

<sup>1</sup> Stainless steel ø2.5 mm wire bracket.

<sup>2</sup> Suitable for trellis rectangular steel profiles; 50 x 25, 50 x 30, 50 x 40 mm.

<sup>3</sup> Suitable for trellis rectangular steel profiles; 60 x 25, 60 x 30, 60 x 40 mm.

<sup>4</sup> 3 x 2.08 mm<sup>2</sup> (AWG14) wire conductors

<sup>5</sup> 3 x 1.5 mm<sup>2</sup> conductors, 2-sided 'male / female connector.

<sup>6</sup> To ensure IP66 compliance for every single mounted or last module in a continuous or non-continuous line!

# Accessory information

## Accessories for module

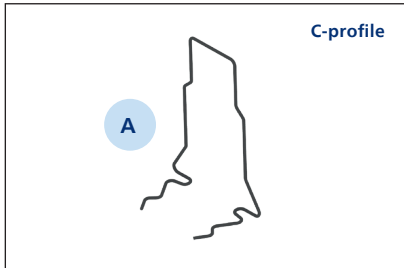

GPL bracket toplighting NAM



GPL bracket toplight\_2.0/2.1 TRE 50

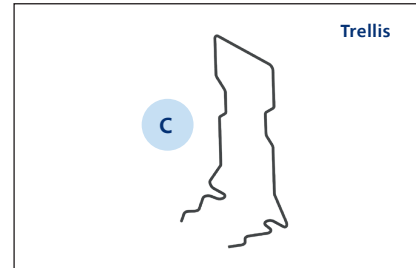

GPL bracket toplight\_2.0/2.1 TRE 60

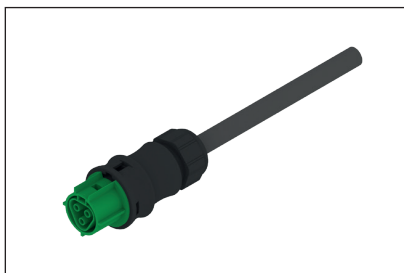

GPL toplighting main power cable

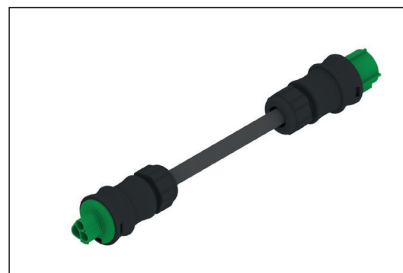

GPL toplighting jumper NAM 3.3ft/6.6ft

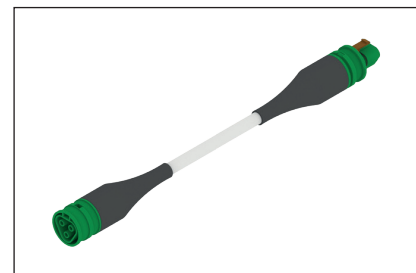

GPL toplighting jumper EU

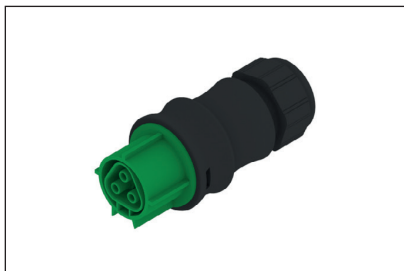

GPL toplighting female connector



GPL toplighting male connector



End cap

# Crop protection and cleaning products

## **Use of cleaning agents, crop protection products and other chemicals**

Philips Horticulture GreenPower LED products are engineered to meet the highest standards in daily usage and are compatible with the most commonly used crop protection products and cleaning products in the field. However, there are some crop protection products and cleaning agents that may damage the protective surfaces of the GreenPower LED products and should be avoided. Please ensure that you take the following instructions into account when cleaning the GreenPower LED products, your facility, or when using crop protectors.

## **Cleaning GreenPower LED products**

- Turn off and disconnect the power before cleaning the product.
- Use a soft damp cloth to remove dust or dirt from the GreenPower LED product.
- Do not use rough or coarse-grained materials, scouring pads, bleach or solvents.
- The use of a non-approved cleaning product or solvent could scratch or damage the GreenPower LED product.
- IP66 covers 100Kpa = 1 bar water pressure. To avoid damaged gaskets Signify advises NOT to clean this product with water power jets.

# Compliance with international standards

The GreenPower LED toplighting linear gen 2.2 module has been tested and/or certified for and complies with the following international standards. Details are described in Declaration of Conformity "DoC TMg2.2 DK <xxxxx>-UL".

Test	Stress type	Standard
Mechanical integrity	Static cable pull	
	Dynamic cable pull	
	Bump test	IEC 68-2-29 Eb
	Vibration variable test	JEC 68-2-6
Endurance	Cold temperature storage	IEC 68-2-1 Ab
	High temperature storage	IEC 68-2-2 Bb
	Damp heat (temp. humidity)	IEC 68-2-30 Db
	Temperature shock	IEC 68-2-14 Nb
	Ingress protection	IEC 60529 IP66
Quality / Environment	Environmental standard	ISO 14001
	Toxic materials	Directive 2011/65/EU
EMC	Generated disturbances to the environment	EN 55015
		CISPR 15
		IEC 61000-3-2
		IEC 61000-3-3
	Immunity	IEC 61547
Safety		IEC 60598
		IEC 62471
		UL 8800
		CSA c22.2 No. 250.0-08
Approval marks	Approval marks GreenPower LED toplighting	ENEC
	Declaration of conformity	CE
		cULus

© 2023 Signify Holding. All rights reserved. The information provided herein is subject to change, without notice. Signify does not give any representation or warranty as to the accuracy or completeness of the information included herein and shall not be liable for any action in reliance thereon. The information presented in this document is not intended as any commercial offer and does not form part of any quotation or contract, unless otherwise agreed by Signify.

Philips and the Philips Shield Emblem are registered trademarks of Koninklijke Philips N.V.  
All other trademarks are owned by Signify Holding or their respective owners.

Document order number: 4422 952 16769 B  
10/2023  
Data subject to change



**For more information about**  
Philips Horticulture LED Solutions visit:  
[www.philips.com/horti](http://www.philips.com/horti)  
Write us an e-mail:  
[horti.info@signify.com](mailto:horti.info@signify.com)  
Or tweet us:  
[@PhilipsHorti](https://twitter.com/PhilipsHorti)